



TEREX

TV1000-1 & TV1200-1

Tandem Asphalt Rollers

OPERATING WEIGHT	5,644 / 6,382 lbs (2,560 / 2,895 kg)
NET ENGINE POWER	30 hp (22.5 kW)
STATIC LINEAR LOAD	71.7 / 67.5 lbs/in (12.0 / 13.9 kg/cm)
CENTRIFUGAL FORCE	5,397 / 6,776 lbs (24.0 / 30.4 kN)



TANDEM ASPHALT ROLLERS

Operating Data, Standard Equipment

	TV1000-1	TV1200-1
Operating weight	5,644 lbs (2,560 kg)	6,382 lbs (2,895 kg)
Basic weight	5,238 lbs (2,376 kg)	5,977 lbs (2,711 kg)
Static linear load	71.7 lbs/in (12.0 kg/cm)	67.5 lbs/in (13.9 kg/cm)
Total length	93.5 in (2,375 mm)	93.5 in (2,375 mm)
Total width	42.12 in (1,070 mm)	50 in (1,270 mm)
Turning radius (inside)	103 in (2,625 mm)	99 in (2,525 mm)
Total height	104.33 in (2,650 mm)	104.33 in (2,650 mm)
Frame articulation degrees	30°	30°
Frame oscillation degrees	15°	15°
Frequency (Hz) VPM	3,120 (51 Hz)	3,120 (51 Hz)
Amplitude	.022 in (0.6 mm)	.022 in (0.6 mm)
Centrifugal Force	5,397 lbs (24.0 kN)	6,776 lbs (30.4 kN)
Gradeability % (with vibration on)	30%	30%
Gradeability % (with vibration off)	40%	40%
Drum thickness	.78 in (20 mm)	.51 in (13 mm)

Tandem Asphalt Rollers

TV1000-1 & TV1200-1

Specifications

Engine	
Manufacturer, model	Deutz, F2L 1011F
Type	2-cylinder, diesel engine
Power rating at 2,500 rpm	30 hp (22.5 kW)
Cooling system	Air
Electrical System	
Nominal voltage	12 Volt
Battery	770 CCA
Alternator	65 Amp
Hydrostatic Transmission	
Hydrostatic drive. Forward and reverse selected from joystick. Infinitely variable speed control forward and reverse. 0 – 7.2 mph (0 – 11.6 km/h)	
Drive	
Dual radial piston drive motors.	
Brakes	
Service brake: Hydrostatic drive provides dynamic braking.	
Parking brake: Spring applied failsafe	
Steering	
Heavy-duty articulated steering	
Fluid Capacities	
Fuel tank	11.6 gal (44 L)
Hydraulic system (includes tank)	11.6 gal (44 L)
Water tank	47.5 gal (180 L)
Operator's Area	
Open operator's seat with functional design, excellent all-round visibility and user-friendly operator controls.	
Operator's suspension seat with hydraulic cushioning and lap belt; weight, height and longitudinally adjustable.	

Standard Features

Vandal protection package
Back-up alarm
2 scraper bars per drum
Hydraulic test points
Electrical diagnostics system (LED lights)
Tow valve
12 volt battery disconnect
Pressure and gravity water
ROPS

Dimensions

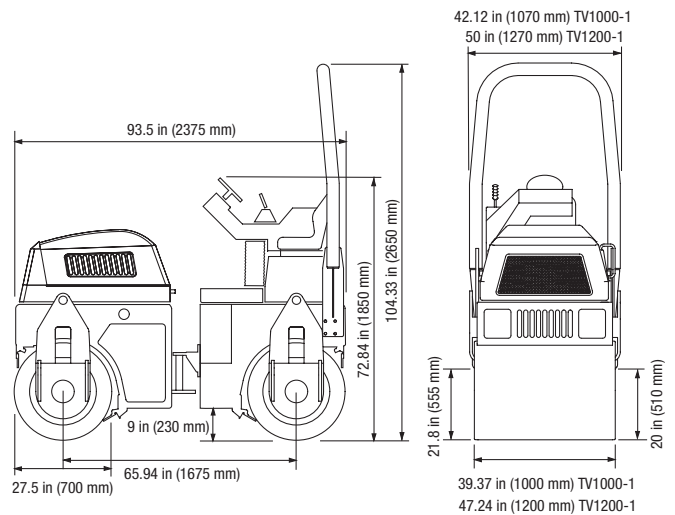

TEREX Construction Americas

8800 Rostin Road
Southaven, MS 38671
USA

TEL 662-393-1800
SALES 866-837-3923
PARTS & TECH SUPPORT 888-201-6008
FAX 662-393-1700
EMAIL sales@terexca.com
WEB terexca.com

For more information, product demonstration, or details on purchase, lease and rental plans, please contact your local TEREX Distributor.

Effective date: January 1, 2005. For further information, please contact your local distributor or the TEREX sales office listed. Continuous improvement of our products is a TEREX policy. Product specifications are subject to change without notice or obligation. The photographs and drawings in this brochure are for illustrative purposes only. Refer to the appropriate Operator's Manual for instructions on the proper use of this equipment. Failure to follow the appropriate Operator's Manual when using our equipment or to otherwise act irresponsibly may result in serious injury or death. Prices and specifications subject to change without notice. The only warranty applicable is the standard written warranty applicable to the particular product and sale. TEREX makes no other warranty, expressed or implied. Products and services listed may be trademarks, service marks or trade-names of TEREX Corporation and/or its subsidiaries in the USA and other countries and all rights are reserved. "TEREX" is a Registered Trademark of TEREX Corporation in the USA and many other countries. Copyright ©2005 TEREX Corporation

TV1000-1/TV1200-1 5K 0505B Part #109039